

Thank You for choosing Event Tap 1071-1

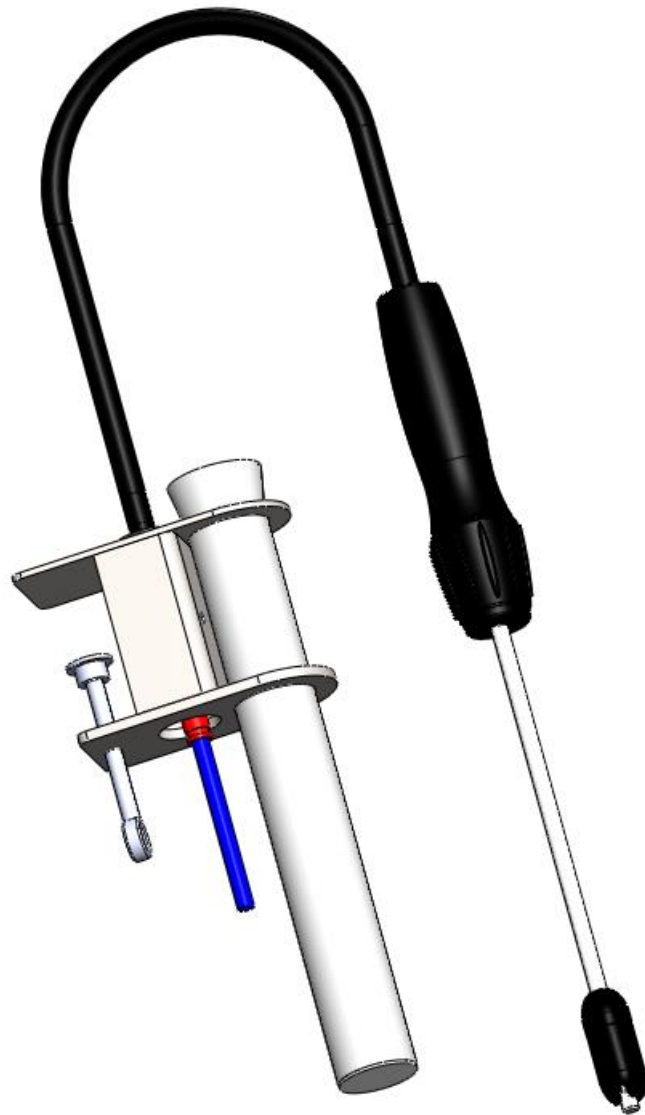

Event Tap 1071-1

Event Tap is designed for dispensing beer from kegs or tanks.

Event Tap can be used indoors and outdoors. Event Tap has a maximum capacity of 7-8 liters of beer per minute, depending on temperature of the beer.

Please read the entire user manual carefully before you use Event Tap for the first time.

Pay attention to the limitations and warnings outlined in the manual.

The User Manual shall always be kept with the equipment.

Event Tap is CE marked.

Event Tap is patent pending by Event Dispense.

Contents:

THANK YOU FOR CHOOSING EVENT TAP 1071-1 1

EVENT TAP 1071-1 2

CONTENTS: 3

SAFETY GUIDELINES:..... 4

INSTALLATION: 4

TEMPERATURE AND FLOW RATE: 4

TEMPERATURE AND PRESSURE: 5

OPERATION: 6

TROUBLESHOOTING 1:..... 7

TROUBLESHOOTING 2:..... 8

DISASSEMBLING THE EQUIPMENT: 9

CLEANING THE EQUIPMENT:.....10

DAILY CLEANING:.....11

ASSEMBLING AFTER CLEANING:.....11

BEFORE USE:.....11

SPARE PARTS:11

WARRANTY:11

SPARE PARTS LISTING ET1071-1:.....12

Safety Guidelines:

Event Tap must not be exposed to pressures greater than 3 bars / 45 psi.

Event Tap must not be exposed to pressure at ambient temperatures exceeding 50 degrees Celsius.

Event Tap must only be used for beer, soft drinks and plain water. The warranty does not cover defects or damages directly or indirectly caused by misuse.

Event Tap must not be cleaned with dish wash soap or with water over 85 degrees Celsius.

Installation:

Connect your beer line to the John Guest speed fitting (Item 6) on the Event Tap or to the Restrictor Tube (Item 4), this is depending on the installation, see Figure 9. When using the Event Tap it is recommended to use a ice-bank beer cooler, the beer cooler must have a coil on 26-30 meters, the internal diameter of the coil must be 7-8mm. It is important that the beer line connected to the Event Tap, is isolated and cooled with circulating ice water.

Temperature and Flow Rate:

Dispense temperature should be between: 1°C - 3° C, see Figure 1 for more information. Contact Event Dispense if you need help to calculate the size of the cooler required to obtain the temperatures shown in Figure 1.

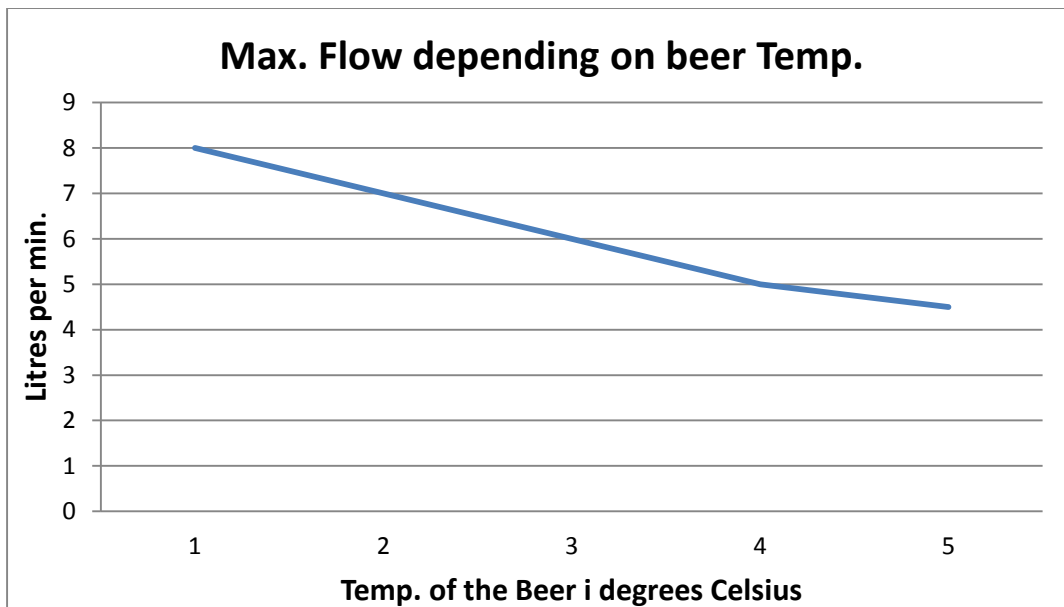

Figure 1: The curve is indicative and is valid for pilsner (pale lager).

Temperature and Pressure:

Recommended system pressure: 1.8 bars - 3 bars, depending on beer type and beer storage temperature. For more information see Figure 2 below.

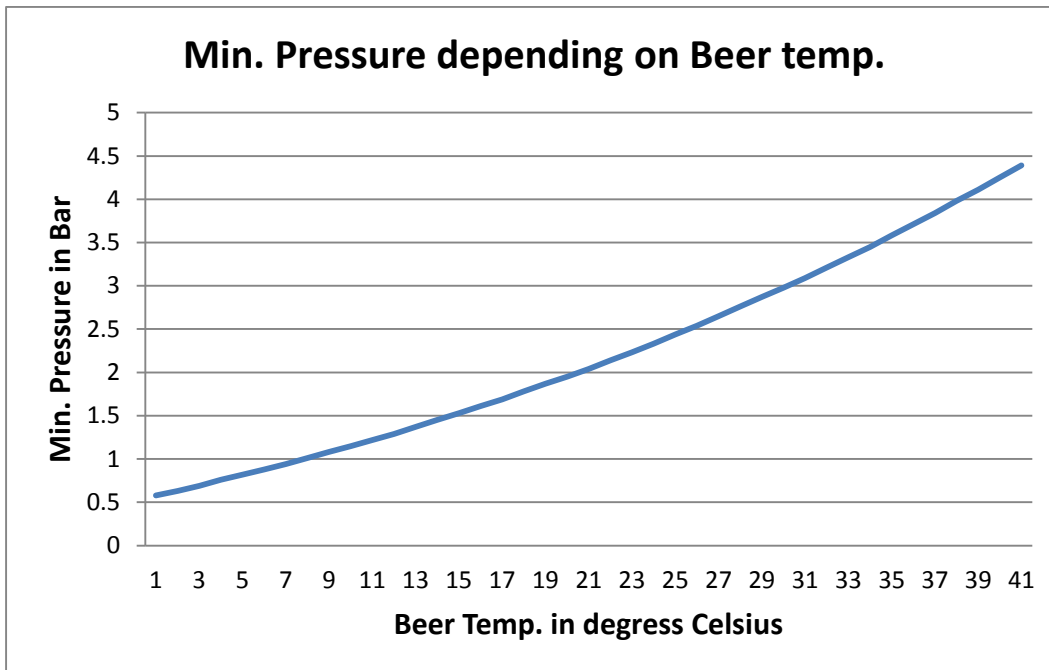

Figure 2: The curve is indicative and is valid for pilsner (pale lager).

Operation:

1. Grasp the handle.
2. Move the valve house to the bottom of the glass as show Figure 3 A.
3. Then press vertically on the Event Tap until the activator (1, Fig.4) moves, there by opening the valve Figure 3 B.
4. Once the valve is open, it is not necessary to maintain the vertical pressure.
5. When the glass is full, lift the Event Tap from the bottom of the glass, and the valve will close automatically.
6. For further instructions, follow the link <http://www.eventdispense.com/products/10>



Figure 3

Troubleshooting 1:

Symptom	Check	Try
Too much foam	Is there air in the system?	Tap a few liters of beer off the system.
	Is the beer temperature too high?	Use a longer coil or connect two coils in a series. If you need help to calculate the minimum size of your cooler or the coil length contact Event Dispense. Precool the keg.
	Is the flow rate too high?	Reduce speed by using a tube with a smaller inner diameter to supply the tap with beer.. Reduce the pressure on the keg or tank.
	Are the glasses of poor quality?	Some disposable plastic glasses are produced with too rough a surface for draft beer. The difference from good glasses may not be visible, but you can check the quality of the plastic glass by comparing the foam production in it with the foam production in a real glass of same size.
	When was the beer last moved?	Avoid violent movements of kegs or tanks for min. 12 hours before taping the beer.
	Has the keg been exposed to carbon dioxide for too long?	Change the keg.
	Is the pressure too low?	If the pressure is below the recommended levels in Figure 2, increase the pressure.
	Is the pressure too high?	If the pressure is more than the recommended pressure + 0,5 bar, reduce the pressure in the following way: Close the valve between the carbon dioxide (CO ₂) flask and the keg/or between compressor and tank. Then vent the keg/tank slowly until the regulator show a pressure below the wanted pressure. Close the vent valve and turn the regulator to the recommended pressure. Open the valve between the carbon dioxide flask and the keg/or between the compressor and tank.
	Has there just been a break in consumption?	Tap a few liters of beer, until the beer gets cold again.

Troubleshooting 2:

Symptom	Check	Try
The beer runs fine until the cup is half full, then the rest of the cup is filled with foam	Is the temperature too high in the tank or keg?	Use a longer coil or connect to coils in series. Pre cool the keg.
No beer is coming out in the glass	Is the keg/tank empty?	Change the keg/tank.
	Are all the valves open?	Open all valves.
	Is the system blocked?	Check for blockages from the keg/tank to the tap.
	Is the pressure OK?	Ensure that the compressor is running or check the pressure in the CO-2 Bottle
Too little foam	Is the pressure too low?	Increase the pressure! (Do not increase the pressure to more than the recommended levels in Figure 2 + 1 Bar.)
	Is there flow to low?	Flow speed can be increased by changing the tube supplying the tap with beer with a tube with a larger inner diameter.
	Is the temperature too low?	Reduce the cooling of the beer
		The valve will produce foam when the activator is in a middle position. Every time you open and close the valve the activator will pass this position twice. Therefore if you want more foam, tap the activator several times against the bottom of the glass/beaker.

If you can't solve the problems, then contact Event Dispense, phone +45 51 76 42 74 or jka@eventdispense.com

Disassembling the equipment:

Event Tap 1071-1 (ET1071-1) is supplied by Event Dispense fully assembled. It looks like one unit. Yet the equipment consists of three main parts:

Valve (1+2), Pipe (3) and Handle (4), see Figure 4. Both the handle, and the valve are units with specific functions and each is built of several parts. Units can be disassembled as shown in the subsequent figures:

In order to separate parts 3 and 4, turn 4 counter clockwise, and then pull 3 out.

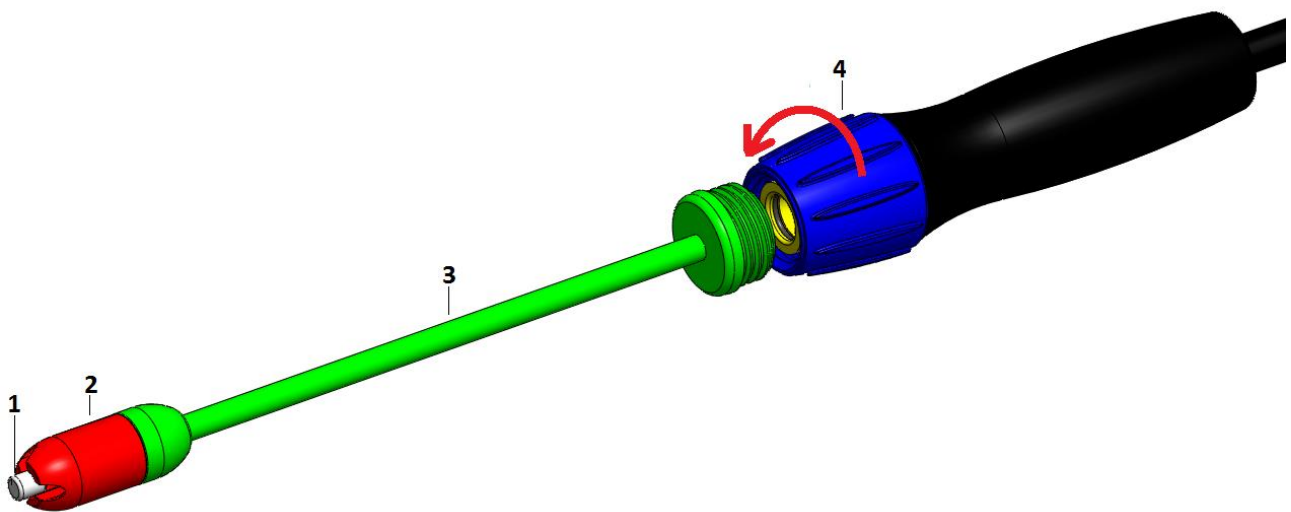

Figure 4

In order to separate the valve (1) and the pipe (2) in Figure 5, turn the valve counter clockwise. Be careful as the Valve Piston will easily fall out (See item 2, Figure 6).

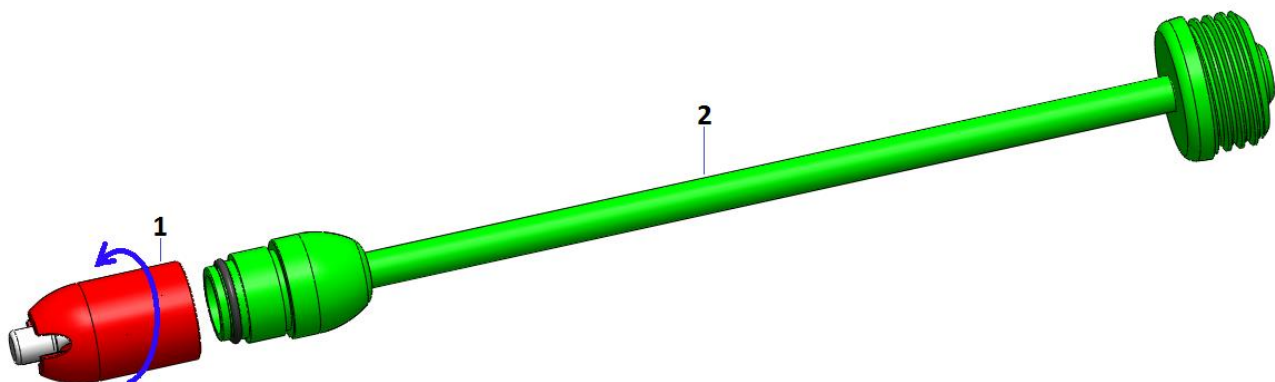

Figure 5

The valve is made of two main parts (see Figure 6): Valve Housing (1) and Valve Piston (2).

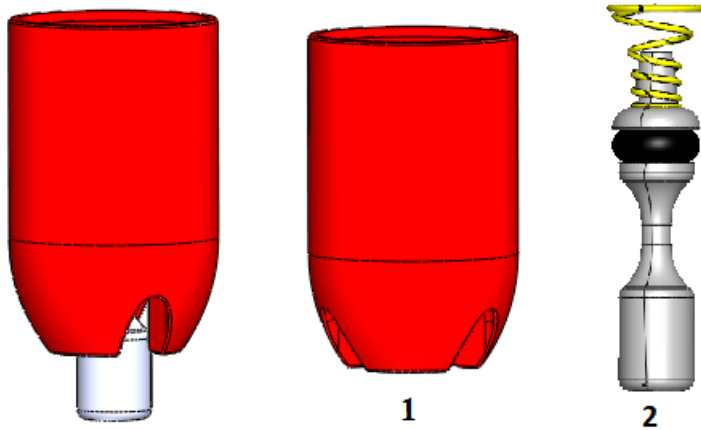

Figure 6

Cleaning the equipment:

To ensure optimal cleaning of the internal of the Event Tap, flood the beer line and Event Tap with standard cleaning fluid approved for the food industry. Chemisphere UK, produce a product which are named “Pipeline” this product can be used for internal cleaning of the Event Tap.

To ensure optimal cleaning of the Event Taps externals, disassemble the unit and wash the parts separately with a brush, then place them in hot water at max. 85° Celsius, or in 85% alcohol (see Figure 7.) IDUNA A/S, produce a product named “IDZ Rapid A” this product can be used for external cleaning of the Event Tap. IDZ Rapid A is an 85% alcohol mixture. **Do not use dish wash soap it will damage the O-rings !**

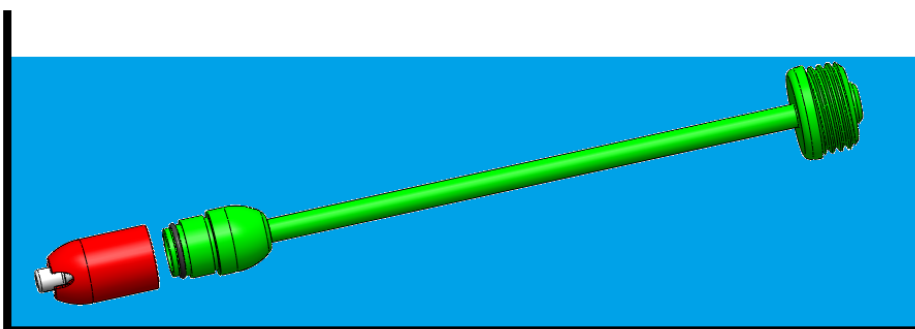

Figure 7

Daily Cleaning:

Clean the externals of the Event Tap when it is needed, e.g. in the morning and when closing down the site. This is done by wiping of the stainless steel pipe with 85% alcohol (IDZ Rapid A) or other cleaning fluids approved for the food industry.

If the system is not going to be used for several hours (e.g. overnight), then fill up the “Cleaning pipe” (See Figure 9, Item 2) with 85% alcohol (IDZ Rapid A) and let it sit there until it is going to be used again. This is done to disinfect the valve housing, and to ensure that the sugar in the beer does not stick to the valve parts and preventing normal function.

Assembling after cleaning:

Immediately before assembling the Event Tap, lubricate the relevant O-rings with water, if you fail to lubricate the O-rings, you can damage them.

Before use:

During transport and storage there will always be a risk that the inside of the equipment will become contaminated with dust from packaging materials.

Dust may be contaminated with bacteria therefore the Event Tap has to be disinfected before use. The easiest way to do this is to flood the system with alcohol or other cleaning fluids approved for the food industry, and then rinse afterwards with copious amount of water.

Spare Parts:

Replace the O-rings if the equipment becomes leaky. O-rings can be obtained from Event Dispense as can other spare parts. See Figure 8 and Figure 9 for Spare Parts info. The anticipated delivery time is 2-4 weeks.

Warranty:

Event Dispense provides a 1 year warranty on the Event Tap 1071-1. Warranty covers manufacturing and material defects discovered during normal use. Warranty does not cover defects or damages directly or indirectly caused by misuse, violence or interference from other than a local dealer / installer. Warranty does not cover O-rings and plastic parts.

Spare Parts Listing ET1071-1:

ITEM NO.	PART NUMBER	DESCRIPTION	QTY.
1	809055	Handle - Event Tap	1
2	809064	Screw M6 x 8	1
3	809063	Silicone Hose 1,2m	1
4	809061	Clamp Ø11,5	1
5	809062	Speedfitting 3/8 inch	1
6	809065	Female Quick Connector - Event Tap	1
7	809059	Pipe for Nozzle - Event Tap	1
8	809032	O-ring 3x3	1
9	809033	O-ring 14 x 1,78	1
10	809034	Valve Piston	1
11	809039	Spring 2,5 Newton	1
12	809051	Valve Seat	1

DESCRIPTION:	EVENT TAP - 1071-1	PART NUMBER:	ET1071-1	A4
WEIGHT:				

Figure 8

Spare Parts Listing Table Clam

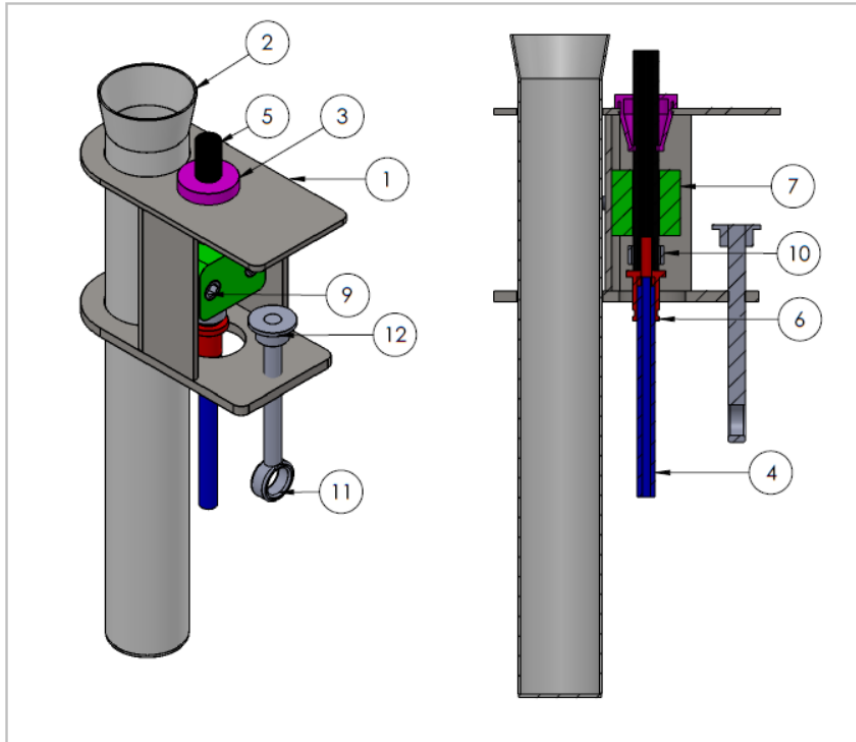

ITEM NO.	Part Number	DESCRIPTION	QTY.
1	04011502	Table Clamp	1
2	04011514	Cleaning Pipe	1
3	04011508	Hose Protector Ø12	1
4	04011513	Depending on the installation 0-30cm	1
5	04011506	Length = 1,2 m	1
6	04011511	Male - Female (DM Speedfitting)	1
7	04011507	Hose Clamp	2
8	04011515	M6 washer	4
9	04011510	M6 x 30	2
10	04011504	Clamp Ø13,3	1
11	04011505	Eye Screw M8 x 80	1
12	04011512	Nut M8	1
Description		Part Number	A4
Table Clamp - 2015		0401201516	

Figure 9